

# PROCEEDINGS OF SPIE

[SPIDigitalLibrary.org/conference-proceedings-of-spie](https://SPIDigitalLibrary.org/conference-proceedings-of-spie)

## Reconfigurable wearable to monitor physiological variables and movement

Romero, Francisco, Morales, Diego, Castillo, Encarnación, García, Antonio, Tahmassebi, Amirhessam, et al.

Francisco J. Romero, Diego P. Morales, Encarnación Castillo, Antonio García, Amirhessam Tahmassebi, Anke Meyer-Baese, "Reconfigurable wearable to monitor physiological variables and movement," Proc. SPIE 10216, Smart Biomedical and Physiological Sensor Technology XIV, 1021608 (16 May 2017); doi: 10.1117/12.2263527

**SPIE.**

Event: SPIE Commercial + Scientific Sensing and Imaging, 2017, Anaheim, California, United States

# Reconfigurable wearable to monitor physiological variables and movement

Francisco J. Romero<sup>a</sup>, Diego P. Morales<sup>\*a</sup>, Encarnación Castillo<sup>a</sup>, Antonio García<sup>a</sup>, Amirhessam Tahmassebi<sup>b</sup>, Anke Meyer-Baese<sup>b</sup>

<sup>a</sup>Dept. Electronics and Computer Technology, University of Granada, 18071 Granada, Spain;

<sup>b</sup>Dept. Scientific Computing, Florida State University, 400 Dirac Science Library, Tallahassee, FL 32306-4120

## ABSTRACT

This article presents a preliminary prototype of a wearable instrument for oxygen saturation and ECG monitoring. The proposed measuring system is based on the light reflection variability of a LED emission on the subject temple. Besides, the system has the capacity to incorporate electrodes to obtain ECG measurements. All measurements are stored and transmitted to a mobile device (tablet or smartphone) through a Bluetooth link.

**Keywords:** Biometric monitoring, heart rate, oxygen saturation, healthcare wearables.

## 1. INTRODUCTION

The continuous monitoring of physiological signals by wearables sensors is a topic of high interest for researches and a transversal field to different science and technologies areas [1]. Even though the immediate applications are usually oriented to hospitalized patients or recreational and sports activities, their extension to extreme professional activities is of great interest. In this case, precise information on the subject's physiological state could facilitate and help leading the subject's activity, or even help preventing a risk situation. A clear example is a soldier deployed in a conflict scenario, where the soldier's physical and physiological state is important from both personal and commanders' points of view. The developed wearable device is focused on these scenarios, where the continuous monitoring of oxygen saturation, as well as ECG, is of great relevance. Based on this, factors such as device weight and size are even more critical than usual for this type of devices. Additionally, the device includes an inertial sensor, which is useful to monitor the subject movement pattern and to develop models to estimate parameters such as velocity, steps or energy usage. Finally, associated to this prototype, an Android app allows to follow in real-time all the monitored parameters. The most relevant concepts related to these types of measurements can be found in the following section, while the third section details the structure of this preliminary prototype. Finally, the Android app is described within the last section.

## 2. OXYGEN SATURATION MONITORING

Oxygen saturation monitoring, best known as pulse oximetry, based on the photoplethysmography is a mature technique used in hospitals. This technique is based on the use of different light wavelengths, red (~660 nm) and infrared (~920 nm), to differentiate oxyhemoglobin from des-oxyhemoglobin in the pulsatile blood [2]. This is possible due to the opposite behavior of oxyhemoglobin absorption spectrum when compared to the des-oxyhemoglobin one.

The existing techniques are two: measuring the light transmitted or the light reflected by tissues, bones and blood vessels using photodetectors. In any case, Figure 1 shows this effect and how the pulsatile component of the arterial blood flow produces a characteristic waveform in the signal captured by the photodetector. This signal is known as photoplethysmography signal, or simply PPG. Besides, the ratio between the relative intensity associated to the different wavelengths can be used to determinate a relationship between des-oxyhemoglobin and oxyhemoglobin, and therefore the oxygen saturation (SpO<sub>2</sub>).

The extremities are the preferred areas to take these measurements by existing instrumentation. Nevertheless, these techniques are not suitable when the user is practicing any kind of sport or physical activity [3].

[\\*diegopm@ugr.es](mailto:diegopm@ugr.es); phone +34 958241000 ext. 2019

On the other hand, there exist devices to measure in the earlobe or in the forehead [2]. However, all these solutions are based on a device which is placed over the individual. In extreme performance applications, any extra weight for the user would be associated to an additional effort and, at the same time, could be a possible cause for loss of concentration. In similar applications to measure ECG, the used instrumentation is oriented to obtaining the heart rate more than a reliable PQRST (P wave – QRS complex – T wave) with clinical information about the subject. In fact, the photoplethysmographic signal contains the heart rate information itself, as it can be observed in Figure 1. MIT researchers have already developed preliminary techniques to measure the ECG in this type of situations, but the signal quality is low. On the other hand, an interesting issue is the capacity of having a biometric identification from the ECG signal of each individual [4].

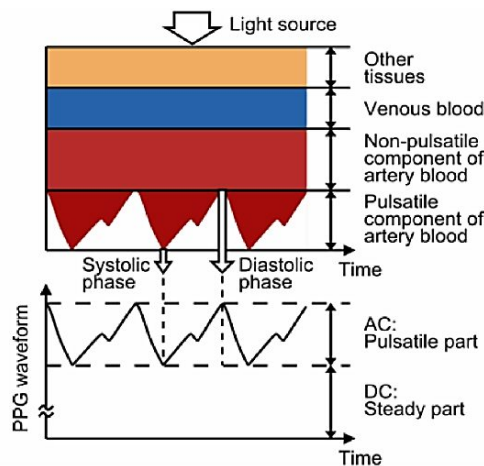

Figure 1. Light absorption contributing factors and expected waveform.

In any case, measurements in the proposed system are obtained by the light reflection method. Only one photodiode is thus required, which makes the device simpler and reduces power consumption. Two LEDs (Light Emitting Diode) generate the light to be reflected, whose wavelengths are associated to the red and infrared spectrum range. In this way, the oxygen saturation can be easily computed as indicated by the Beer-Lambert law [2] in equation (1):

$$SpO_2 = A + B \frac{V_{AC,R} / V_{DC,R}}{V_{AC,IR} / V_{DC,IR}} \quad (1)$$

where the AC and DC terms are referred to the pulsatile and continuous component of the PPG signal respectively, of both red and infrared signals. A and B are calibration constants, which depend on the measuring zone and are both experimentally obtained.

### 3. DEVICE STRUCTURE AND DESIGN

It is clear that the objective of a wearable device is its integration in the tools or clothes the individual usually carry for the activity under monitoring, so it has to be as light as possible in order to not reduce the subject's performance. For example, the integration of the device in the soldiers' equipment (combat helmet, protection glasses, etc.) would allow the auto-monitoring either *in situ* or remotely, with a minimum interference in the combatant activity. The design of this device supposes a technological challenge, as the integration and miniaturization of all this technology, along with the decision of the measuring area. In this sense, the temple area could be an ideal zone to perform the measure of the oxygen saturation, due to the high blood irrigation in this area [5].

On the other hand, it has been demonstrated in recent years that reconfigurable technologies, such as FPGAs (Field-Programmable Gate Array), FPAs (Field-Programmable Analog Array) and SoCs (System-on-Chip), represent an attractive alternative for developing low-cost portable instrumentation for chemical [6] and biomedical [7] analysis. Besides, the availability of mobile devices, such as smartphones or tablets, has taken the field of application of portable devices to new horizons [8], due to the possibility of establishing the communication with these small wearables platforms.

As a result of the union of these paradigms, health wearables and smartphones, this preliminary prototype is a very suitable proof of concept. It includes a PSoC5 LP (Programmable System-on-Chip 5 Low-Power) whose tasks are:

- Photoplethysmographic sensor control, acquisition and reconditioning.
- Heart rate and oxygen saturation estimation from the wave acquired by the photoplethysmographic sensor.
- Inertial sensor control, acquisition and reconditioning for implementing a simple pedometer.
- Bluetooth communication to visualize the data in an external portable device, which is running the associated Android app.

With this in mind, a sensor system has been developed around the PSoC CY8CKIT-001 development kit, and it also includes a complete power supply subsystem. In the following, the main characteristics of the whole system are detailed.



Figure 2. Initial prototype based on the CY8CKIT-001 development kit by Cypress Semiconductor Corp.

### 3.1 PSoC 5LP

The PSoC 5LP family is the first and unique SoC solution based on an ARM Cortex processor integrated with analog and digital reconfigurable resources. Besides, different applications can be designed and programmed in the device making use of a software tool called PSoC Creator. Additionally, Cypress offers a high variety of development kits, which help fast prototyping based on these devices. Thus, the CY8CKIT-001 development kit was selected for this first prototype. The PSoC5 LP functionalities can be summarized as follows:

- High performance 32 bits ARM Cortex-M3 processor.
- Digital subsystem, PLD (Programmable Logic Device) type. This subsystem is formed by the UDBs (Universal Digital Block), whose functions are similar to the basic logic elements of a FPGA. Besides, this subsystem includes some programmable interconnections called DSIs (Digital System Interconnect). In this way, the digital subsystem allows to implement and connect multiple predefined digital blocks, or to implement generic logic. Some of the most common functionalities that can be implemented are serial interfaces (UART, I2C or SPI), counters, timers, PWM generators, etc.
- Analog subsystem. The philosophy is similar to the digital subsystem and its topology is similar to a FPAA. This subsystem includes programmable connections based on buses and analog multiplexers, one high-resolution Delta-Sigma ADC (Analog-to-Digital Converter), two SAR ADCs and four 8-bit DACs (Digital-to-Analog Converter) for both voltage and current. Moreover, it has four configurable blocks based on switched-capacitor technology, which allow the implementation of operational amplifiers with programmable gain, buffers or mixers, and a high precision voltage reference that can be used by the rest of the configurable analog blocks.

### 3.2 Photoplethysmographic sensor

As it was commented in previous sections, the developed photoplethysmographic sensor is very simple. It is formed by two LEDs and only one photodetector [9], in addition to the necessary elements for its polarization. More specifically, the included red [10] and infrared [11] LEDs present a central wavelength of 660nm and 850nm, respectively. Figure 3 illustrates the sensor schematic. The LED emitted luminosity is controlled by a PWM (Pulse Width Modulation) signal generated by the PSoC 5LP. The output signal, once captured by the sensor, is amplified and filtered in the PSoC analog subsystem, for later digital filtering in the PSoC digital subsystem. It must be noted that all this signal path is completely independent of the PSoC processor.

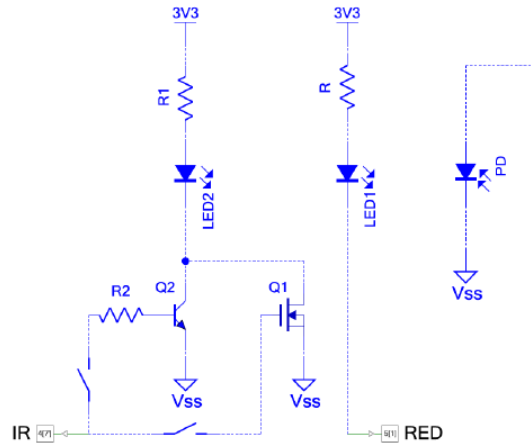

Figure 3. Photoplethysmographic sensor schematic.

### 3.3 Pedometer

The pedometer implemented is based on the InvenSense MPU-6050 [12] integrated circuit, an inertial sensor which is usually used in smartphones and tablets. One of the reasons for using this inertial sensor lies on its small form factor, while it is calibrated during the fabrication process, thus reducing the Time-To-Market. In this first approximation, we have used the GY-521 MPU-6050 development kit, connected to the system in Figure 2, with an I2C communication interface since its PSoC implementation is simpler than other alternatives, such as SPI.

### 3.4 Communications subsystem

It is clear that Wi-Fi and Bluetooth are the most attractive options to communicate a wearable device with any kind of portable device. However, since the system power consumption is a limiting factor in this type of applications, the selected protocol was Bluetooth, even as its range is lower than in the Wi-Fi case. Specifically, the module used is the Wavesen HC-06 [13], which implements Bluetooth 3.0 and is characterized by very low power consumption. In this case, the communication between the PSoC and the Bluetooth module is implemented by a full-duplex UART interface.

### 3.5 Power supply subsystem

The last of the subsystems that form this prototype is the power supply. Due to the low power consumption of the whole system, it can be supplied by a small 120 mAh lithium-ion battery, with CR2450 form factor. In this way, the device can be recharged using a microUSB connector, a *de facto* standard for this type of devices. This eliminates the need of specific chargers.

## 4. ANDROID APP

As it was introduced above, the potential applicability of portable instrumentation has been expanded by the mass usage of mobile devices. Thus, each possible user now carries a powerful hand-held graphical interface for simple interaction through tactile screens, and it is associated to a powerful, usually multi-core, microprocessor. In addition, any smartphone allows the communication by several wireless communication protocols, such as Bluetooth, Wi-Fi or NFC. Therefore, the integration of the developed device with a smartphone app help simplifying device itself, since it eliminates the need of buttons and displays.



Figure 4. Graphical user interface screenshot.

Figure 4 illustrates a screen capture of the Android app, which collects the transmitted data from the instrument through the Bluetooth link. This app also allows the configuration of some user variables, such as height or weight.

## 5. RESULTS

This section shows some results obtained with the reconfigurable instrumental platform of Figure 2, and whose structure was detailed in the previous section. For this, after system calibration following Equation (1), different measurements were taken over different subjects and conditions. To validate the measurements of the developed device, these measurements have been compared with simultaneous measurements from a commercial clinical pulsioximeter, the JPD-500A by Jumper Medical [14].

In this way, Figure 5 illustrates the results for heart rate monitoring of one of these tests, showing data in BPM (Beat Per Minute). In this figure, both sets of measurements, from the developed device and the JPD-500A, are compared, as well as their probability distribution. As it can be seen, the heart rate error referenced to the commercial pulsioximeter is not more than 2 BPM. In a similar way, Figure 6 shows a comparison between SpO<sub>2</sub> measurements obtained by the developed device and the commercial pulsioximeter.

Finally, Figure 7 illustrates the results associated to the step counter of the pedometer. It is precise to emphasize that the relative error in this measurement is inversely proportional to the number of steps given. It is due to the fact that most non-detected steps take place during the start of each test, when the algorithm needs to be autoconfigured and stabilized.

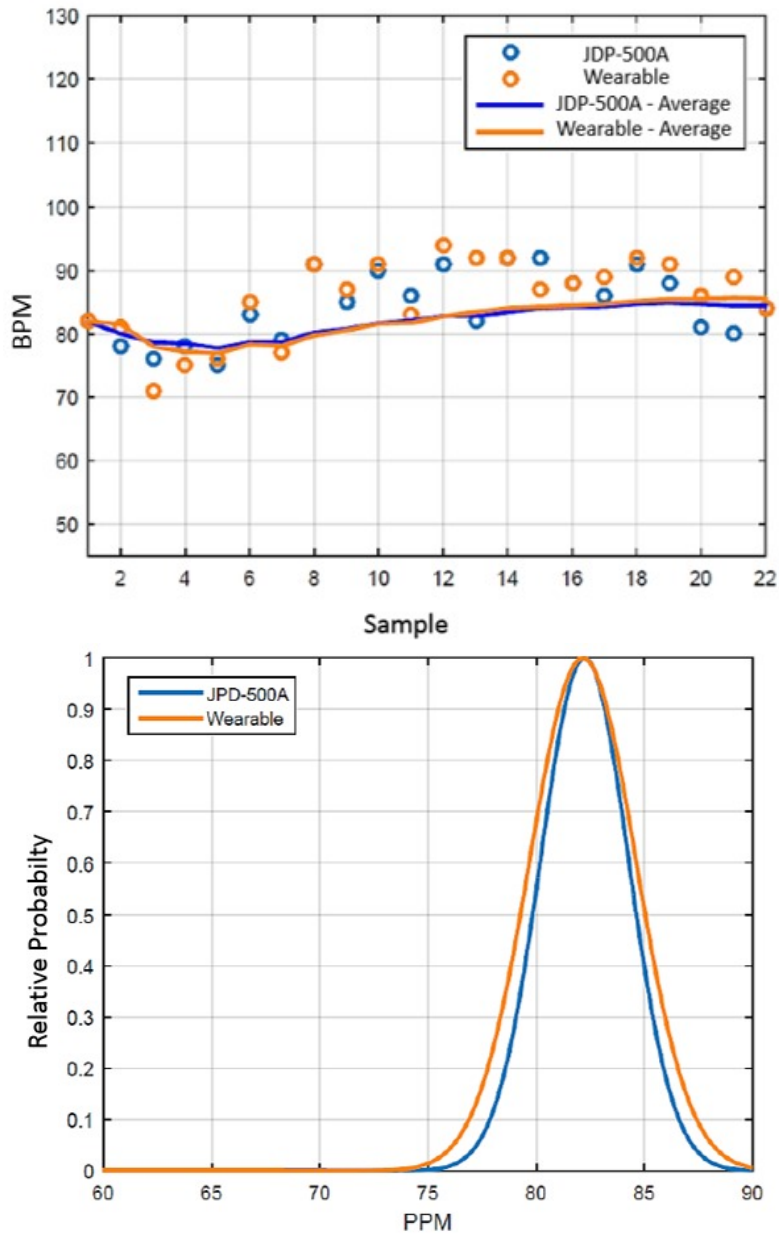

Figure 5. Heart rate measurements from the developed device (wearable) and the commercial pulsioximeter.

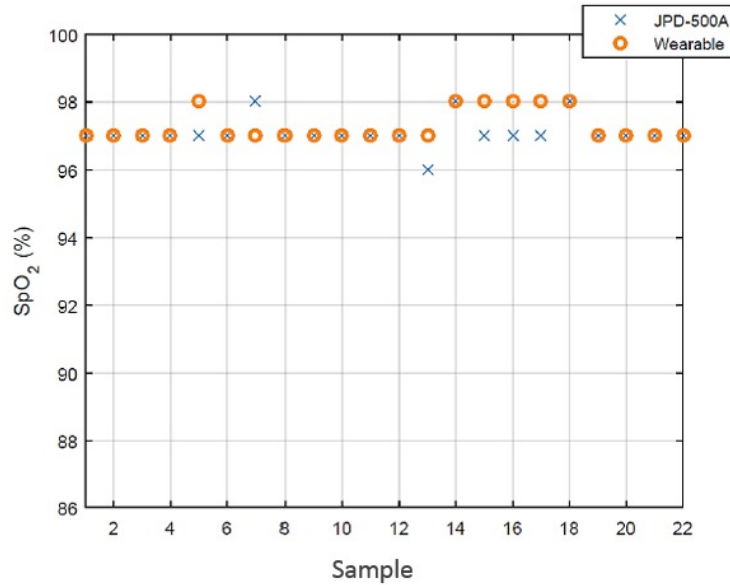

Figure 6. Oxygen saturation measurements from the developed device (wearable) and the commercial pulsioximeter.

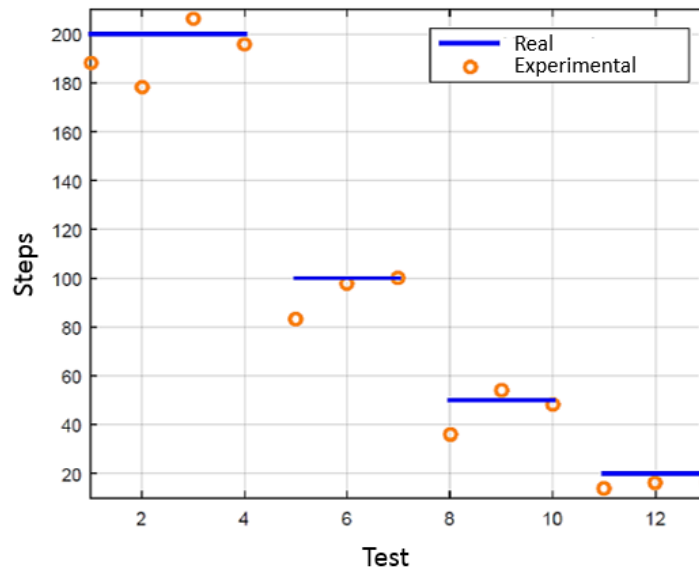

Figure 7. Step counter results for different tests.

## 6. CONCLUSIONS

In this manuscript it has been presented the design and validation of a preliminary prototype for a reconfigurable wearable to monitor physiological variables and movement. The developed device constitutes a low-cost, low-power portable instrument which is able to monitor in real-time the level of oxygen saturation, as well as heart rate. Moreover, it implements a pedometer thanks to the inclusion of an inertial sensor. All measurements are sent through a Bluetooth link to a smartphone, in which an Android app acts as a graphic interface and allows device configuration. The future work associated to this device will deal with the insertion of electrodes for ECG acquisition.



## ACKNOWLEDGEMENTS

This work has been funded by the University of Granada and Training & Indoctrination Command Joint Center (CEMIX UGR-MADOC) under the SIMMA Project (project code 02/16).

## REFERENCES

- [1] Bonfiglio, A. and de Rossi, D., "Wearable Monitoring Systems", Springer Science + Business Media, LLC (2011).
- [2] Toshiyo, T., Maeda, Y. and Yoshida M., "Photoplethysmographic sensors - past and present", *Electronics*, vol. 3, 282-302 (2014).
- [3] Comtois, G., Mendelson, Y., Ramuka, P., "A comparative evaluation of adaptive noise cancellation algorithms for minimizing motion artifacts in a forehead-mounted wearable pulse oximeter", *Proc. 2007 IEEE Conf. Eng. Med. Biol. Soc.*, 1528-1531 (2007).
- [4] Rabhi, E., Lachiri, Z., "Biometric personal identification system using the ECG signal", *Proc. of IEEE Computing in Cardiology Conference CINC '2013*, 507-510 (2013).
- [5] Morales, D. P., Garcia, A., Castillo, E., Carvajal, M. A., Parrilla, L., Palma, A. J., "An Application of Reconfigurable Technologies for Non-invasive Fetal Heart Rate Extraction", *Medical Engineering & Physics*, vol. 35, 1005-10014 (2013).
- [6] Salinas, A., Morales, D. P., Lapresta, A., Ariza, M. Castillo, E., Martinez, E., Palma, A. J., Capitan, L., "Evaluation of a reconfigurable portable instrument for copper determination based on luminescent carbon dots", *Analytical and Bioanalytical Chemistry*, vol. 408, 3013-3020 (2016).
- [7] Ruiz, V. U., Castillo, E., Morales, D. P., Garcia, A., Parrilla, L., Molina, F. S., Florido J., "ECG processing on reconfigurable hardware for efficient artifact reduction", *Experimental & Clinical Cardiology*, vol. 20, 3023-3028 (2014).
- [8] Garcia, A., Erenas, M., Marinetto, E. D., Abad, C. A., De Orbe, I., Palma, A. J., Capitan, L., "Mobile phone platform as portable chemical analyzer", *Sensors and Actuators B (Chemical)*, vol. 156, 350-359 (2011).
- [9] Hamamatsu Photonics, "S2387-66R Datasheet", [http://www.hamamatsu.com/resources/pdf/ssd/s2387\\_series\\_kspd1033e.pdf](http://www.hamamatsu.com/resources/pdf/ssd/s2387_series_kspd1033e.pdf) (2015).
- [10] KingBright, "L-934LSRD Datasheet", <http://www.farnell.com/datasheets/67047.pdf> (2006).
- [11] OSRAM, "SFH4350 Datasheet", [http://www.osram-os.com/Graphics/XPic7/00211319\\_0.pdf/SFH%204350.pdf](http://www.osram-os.com/Graphics/XPic7/00211319_0.pdf/SFH%204350.pdf) (2015).
- [12] InvenSense, "MPU-6000 and MPU-6050 Product Specification", [https://store.invensense.com/datasheets/invensense/MPU-6050\\_DataSheet\\_V3%204.pdf](https://store.invensense.com/datasheets/invensense/MPU-6050_DataSheet_V3%204.pdf) (2013).
- [13] Wavesen, "HC-06 Product Datasheet", <https://www.olimex.com/Products/Components/RF/BLUETOOTH-SERIAL-HC-06/resources/hc06.pdf> (2011).
- [14] Jumper Medical, "JPD-500A Pulse Oximeter Details", [http://www.jumper-medical.com/index.php/pro\\_view/39](http://www.jumper-medical.com/index.php/pro_view/39) (2016).